

## Recommended Installation Instructions

### DO NOT CONNECT OR DISCONNECT WIRING IN A HAZARDOUS ENVIRONMENT!

- Securely mount the 1950-136L 5A SLA Solar Battery Charge Controller in an approved enclosure near the battery to be charged. The charge controller may be bolted to a back plate using the available mounting flanges, or an approved adhesive may be used to attach the charge controller to an available flat surface.
- Run wire from the charge controller's terminals to the battery. 18 gauge wire is recommended if the solar panel provides 1 Amp or less charging current; 14 gauge wire is recommended if the solar panel provides more than 1 Amp of charging current. Strip the wire back 3mm (~1/8") and insert the bare portion into the terminal, then tighten the screw until it crimps down securely on the wire. An approved in-line fuse holder should be wired in series between +BAT terminal of the charge controller and the positive terminal of the battery. A 5 Amp fast-blow style fuse is recommended for circuit protection. If the battery terminals are connected backwards the LED on the charge controller will light indicating reverse wiring and the charge controller will not charge the battery.
- Run cable from the solar panel through the bottom of the enclosure or provided cable entrance to the +IN and GND terminals on the charge controller. Strip the wire back 3mm (~1/8") and insert the bare portion into the terminal, then tighten the screw until it crimps down securely on the wire. If the battery enclosure is located in a potentially hazardous area, ensure use of conduit or approved cable and properly seal all wiring entrances as required.
- Wiring LOAD to the LVD is optional.** If the LVD is not used or the option is not present, LOAD+ and LOAD- should be wired to BAT+ and BAT- respectively.

## WIRING

GND	-Negative terminal of the solar panel (or other source of charging power)
+IN	-Positive terminal of the solar panel (or other source of charging power)
GND	-Negative battery terminal
+BAT	-Positive battery terminal
GND	-System load ground
LOAD	-System load <span style="float: right;">LOW-VOLTAGE DISCONNECT OPTIONAL</span>

## WIRING DIAGRAM

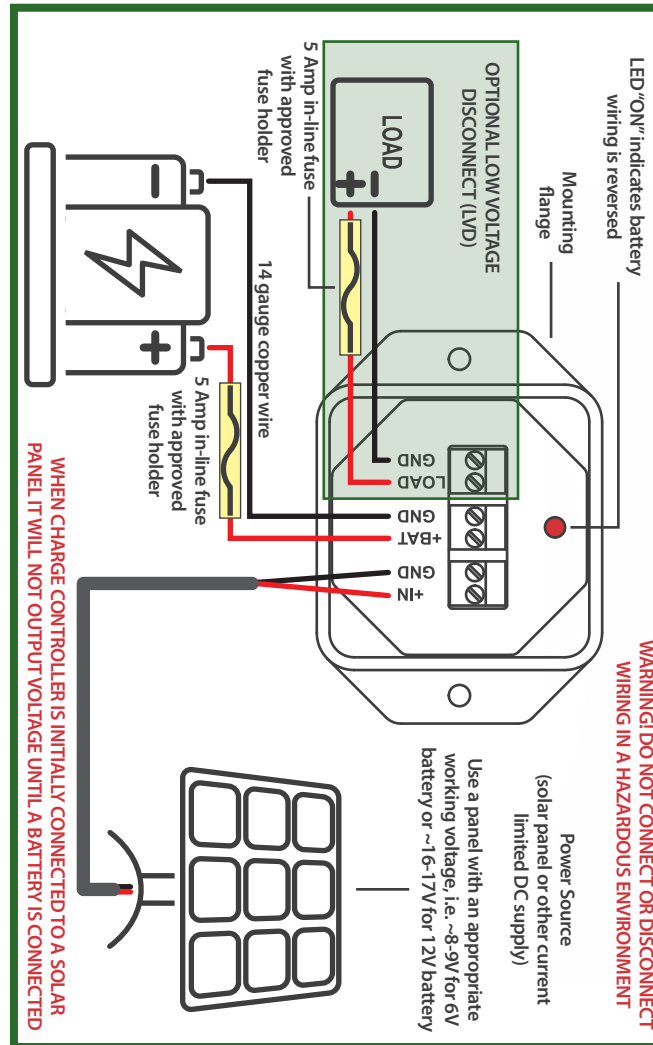

USE THE INCLUDED STICKER MOUNTING TEMPLATE TO CONVENIENTLY PLACE YOUR SOLAR BATTERY CHARGE CONTROLLER

# 6 / 12 Volt - 5 Amp SLA SOLAR BATTERY CHARGE CONTROLLER

Part No. 1950-136L

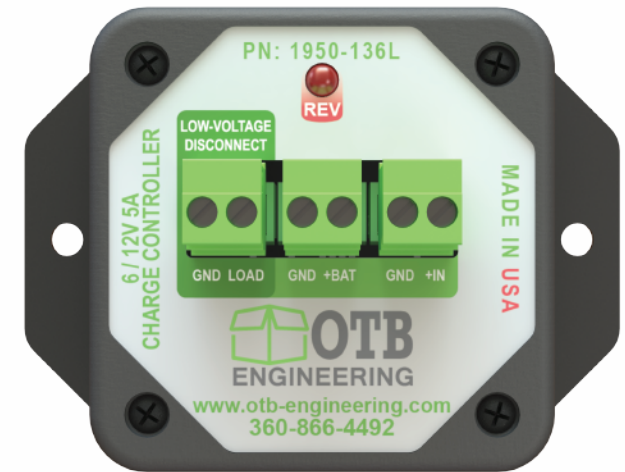

400  $\mu$ A Industry Leading  
Low Self Consumption

 **OTB**  
ENGINEERING

## JUMPER SETTINGS

To gain access to the jumpers, remove the plug-in connectors and the four screws from the corners of the cover. There are three sets of jumpers across the bottom.

### 12V / 6V

There is one jumper to select between 12V and 6V. The leftmost set has four pins. Place the jumper across the left two pins for 12V operation (**this is the factory default**). Place the jumper across the right two pins for 6V operation. If this jumper is not installed, the charger defaults to 6V operation.



**For chargers with LVD, the jumper MUST be present in either the 12V or 6V position.**

Throughout this document “paired” voltage levels are used to describe operating parameters. The first number will represent 12V operation. The second number in parenthesis ( ) will represent 6V operation.

### FAST CHARGE



The middle set of jumpers is used to enable the fast charge mode. With this jumper in place the charger will immediately go into the fast charge mode when the battery voltage falls below 12.8V (6.4V). The charger will fast charge the battery to 14.7V (7.4V) and enter a compensation mode. When the charging current falls off indicating the battery has been charged, the fast charge turns off. **This jumper in place is the factory default setting. For gel cell batteries this jumper should be removed.**

### FLOAT CHARGE



The right set of jumpers is used to enable the float charge mode. With this jumper in place the charger will maintain a battery voltage of 14.1V (7.0V). This will hold the battery in a fully charged state. The charge controller enters this state automatically whenever the fast mode shuts off. **This jumper in place is the factory default setting.**

**At least one of the jumpers for Fast/Float must be in place for the charger to operate.** For AGM SLA batteries, both jumpers should be left in place to enable the charge controller to select the best charging method for the battery and to prolong battery life.

## TEMPERATURE COMPENSATION

The charge controller has built-in temperature compensation. The charger should be mounted in the battery box near the battery for optimal compensation.

### REVERSE BATTERY INDICATOR

If the battery is wired with the positive and negative terminals reversed, the red Reverse Battery LED will light. The controller is internally protected from damage from reverse wiring on both the solar and battery terminals, but must be wired correctly to charge the battery.

### CHARGING PARAMETERS

When the battery drops below approximately 2.13V per cell the charge controller will enter a fast charge mode. The charge controller will supply the maximum current possible to the battery until the terminal voltage reaches approximately 2.45V per cell. As the battery approaches a fully charged state, the charge controller enters a compensation charging mode and the charging current will taper off. When the current reaches a steady state value, the charge controller will switch to the float charge mode. The charge controller will then supply current to the load and will also maintain the battery at approximately 2.35V per cell as long as charging power is available.

Due to the low noise linear charge method used by this product, it is possible to overheat a unit by using a power supply or solar panel with a working voltage much higher than the battery voltage. Appropriate power dissipation in the charge controller may be best maintained by using a solar panel or power supply with a working voltage of approximately 8 – 9 volts for 6 volt batteries and 16-17 volts for 12 volt batteries.

### LOW-VOLTAGE DISCONNECT (LVD)

The LVD protects a load from damaging low voltages and prevents a deep discharge of the battery during an extended power outage. The LVD will automatically disconnect the battery when voltage falls below the the cutoff voltage. When power is restored the LVD will automatically reconnect the battery.

## DIMENSIONS

Inches [Millimeters]

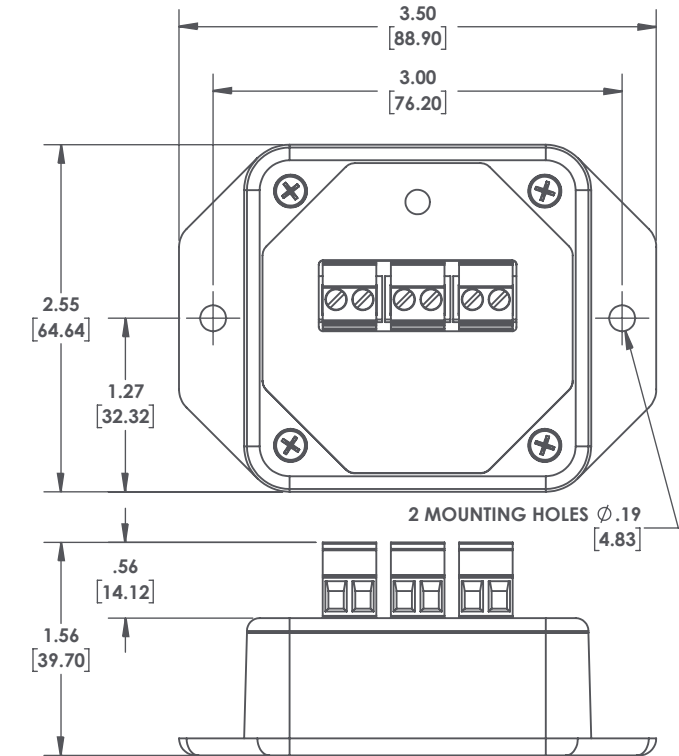

## SPECIFICATIONS

Battery Voltage	12V / 6V
Max Charge Current	5 Amps
Charging Modes	Fast (jumper selected) Float (jumper selected) Fast / Float (jumper selected)
Fast / Compensation Mode ON Voltage	~12.8V (6.4V)
Fast / Compensation Mode OFF Voltage	~14.7V (7.4V)
Float Mode Voltage	~14.1V (7.0V)
Self-Consumption	400 $\mu$ A (not charging), 2mA (charging)
Self-Consumption w/ LVD	550 $\mu$ A (not charging), 2.15mA (charging)
Temperature Compensation	-3.3mV / deg C / Cell
LVD Disconnect/Reconnect Voltage	10.6VDC / 12.3VDC (5.7VDC / 6.2VDC)
Max Load Current	5 Amps
Operation Temperature	-40 to 60 deg C
Pluggable Connectors	12 AWG max

